

Solutions last updated: February 03, 2025

1 True or False

- 1.1 On a fast cross-continental link (~100Gbps), **propagation delay** usually dominates **end-to-end packet delay** (Most messages are smaller than 100MB).

True. On a 100Gbps link, even a 100MB file download would only take 0.008 seconds to get on the wire, compared to 0.02 seconds propagation delay from New York to London (in the best case). Most communications (web page, emails) don't come close to this size.

- 1.2 On the same cross-continental link (~100Gbps), when transferring a 100GB file, **propagation delay** still dominates end-to-end file delivery.

False. Sending a 100GB file over a 100Gbps link will have at least 8 seconds transmission delay.

- 1.3 On-demand circuit-switching is adopted by the Internet.

False. Circuit-switching shares bandwidth through reservation. Packet-switching shares bandwidth on demand. Packet-switching is adopted by the Internet.

- 1.4 The aggregate (i.e., sum) of peaks is usually much larger than peak of aggregates in terms of bandwidth usage.

True. Statistical multiplexing leverages this to use available scarce resources more effectively.

- 1.5 Bursty traffic (i.e., when packet arrivals are not evenly spaced in time) always leads to queuing delays.

False. Queuing delay happens when arrival rate is larger than transmission rate (ignoring processing delays). Bursty traffic does not necessarily imply arrival rate is larger than transmission rate. Queuing delay depends on traffic patterns, router internals, and link properties.

2 End-to-End Delay

Consider the diagram below. Link 1 has length L_1 m (where m stands for meters) and allows packets to be propagated at speed $S_1 \frac{m}{sec}$, while Link 2 has length L_2 m but it only allows packets to be propagated at speed $S_2 \frac{m}{sec}$ (because the two links are made of different materials). Link 1 has transmission rate $T_1 \frac{bits}{sec}$ and Link 2 has transmission rate $T_2 \frac{bits}{sec}$.

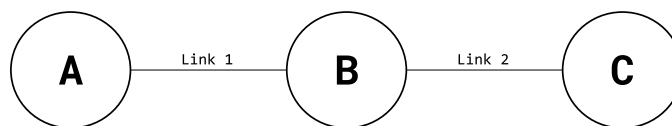

Assuming nodes can send and receive bits at full rate and ignoring processing delay, consider the following scenarios:

- 2.1 How long would it take to send a packet of 500 Bytes from Node *A* to Node *B* given $T_1 = 10000$, $L_1 = 100000$, and $S_1 = 2.5 * 10^8$?

The total time needed is the sum of the transmission delay to push the packet onto Link 1 and the propagation delay for the packet to travel from Node *A* to Node *B*.

$$t_{\text{total}} = t_{\text{transmission}} + t_{\text{propagation}}$$

$$t_{\text{total}} = \frac{\text{packet size}}{\text{transmission rate of Link 1}} + \frac{\text{distance between A and B}}{\text{propagation speed}}$$

$$t_{\text{total}} = \frac{500B * 8 \frac{b}{B}}{10000 \frac{b}{s}} + \frac{100000m}{2.5 * 10^8 \frac{m}{s}}$$

$$t_{\text{total}} = 0.4s + 0.0004s = \boxed{0.4004s}$$

Notice that transmission delay dominates more than 99.9% in this case.

- 2.2 Compute RTT (round trip time) for a packet of *B* Bytes sent from Node *A* to Node *C* (packet gets transmitted back from Node *C* immediately after Node *C* receives it).

There is only one packet, so no need to worry about queuing delays. Consider the diagram below:

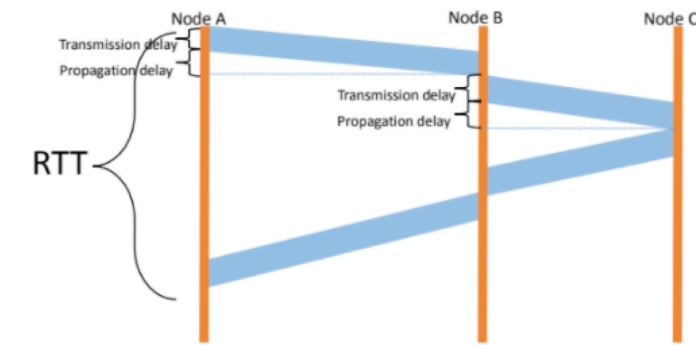

Note the sequence of delays the packet experiences during its route from *A* to *C*:

- Transmission delay to push the packet onto Link 1.
- Propagation delay as the packet travels from Node *A* to Node *B*.
- Transmission delay to push the packet onto Link 2.
- Propagation delay as the packet travels from Node *B* to Node *C*.
- Transmission delay to push the packet onto Link 2.
- Propagation delay as the packet travels from Node *C* to Node *B*.
- Transmission delay to push the packet onto Link 1.
- Propagation delay as the packet travels from Node *B* to Node *A*.

Summing these delays yields the total RTT:

$$\frac{8B}{T_1} + \frac{L_1}{S_1} + \frac{8B}{T_2} + \frac{L_2}{S_2} + \frac{8B}{T_2} + \frac{L_2}{S_2} + \frac{8B}{T_1} + \frac{L_1}{S_1}$$

- 2.3 At time 0, Node A sends packet P_1 with D_1 Bytes and then it sends another packet P_2 with D_2 Bytes immediately after it pushes all bits of P_1 onto Link 1. When will Node C receive the last bit of P_2 ?

There are two packets, so we might need to consider queueing delays.

There will be a queueing delay at Node B if P_2 arrives at B before P_1 is finished being pushed onto Link 2.

Let's start by computing the time at which P_1 finishes being pushed onto Link 2. P_1 takes $\frac{8D_1}{T_1}$ seconds to be pushed onto Link 1, $\frac{L_1}{S_1}$ seconds to propagate from Node A to Node B , and then $\frac{8D_1}{T_2}$ seconds to be pushed onto Link 2. Hence P_1 leaves Node B at time:

$$t_1 = \frac{8D_1}{T_1} + \frac{L_1}{S_1} + \frac{8D_1}{T_2}$$

Next, let's figure out the time when P_2 arrives at Node B . It first waits $\frac{8D_1}{T_1}$ seconds for P_1 to be completely pushed onto Link 1, then takes $\frac{8D_2}{T_1}$ seconds of transmission delay to be pushed onto Link 1 itself, before finally needing $\frac{L_1}{S_1}$ seconds of propagation delay to reach Node B . With this, we know that P_2 reaches Node B at time:

$$t_2 = \frac{8D_1}{T_1} + \frac{8D_2}{T_1} + \frac{L_1}{S_1}$$

There's queueing delay if $t_1 > t_2$, and the length of the delay can be expressed as:

$$t_1 - t_2 = \left(\frac{8D_1}{T_1} + \frac{L_1}{S_1} + \frac{8D_1}{T_2}\right) - \left(\frac{8D_1}{T_1} + \frac{8D_2}{T_1} + \frac{L_1}{S_1}\right) = \frac{8D_1}{T_2} - \frac{8D_2}{T_1}$$

With this analysis in hand, we can express the time at which Node C receives the last bit of P_2 as follows:

$$t_{\text{total}} = \frac{8D_1}{T_1} + \frac{8D_2}{T_1} + \frac{L_1}{S_1} + \max\left(\left(\frac{8D_1}{T_2} - \frac{8D_2}{T_1}\right), 0\right) + \frac{8D_2}{T_2} + \frac{L_2}{S_2}$$

From left to right, the terms in this sum are:

- The transmission delay to push P_1 onto Link 1.
- The transmission delay to push P_2 onto Link 1.
- The propagation delay as P_2 travels from Node A to Node B .
- The queueing delay at Node B . Note that the use of the max operator allows us to express the two cases when there is and when there isn't queueing delay compactly.
- The transmission delay to push P_2 onto Link 2.
- The propagation delay as P_2 travels from Node B to Node C .

4 *Packets in Flight*

Below is the time-graph of a packet in flight without queuing delay:

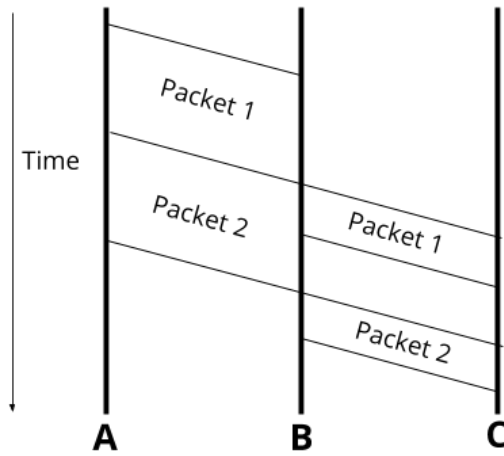

And with queuing delay:

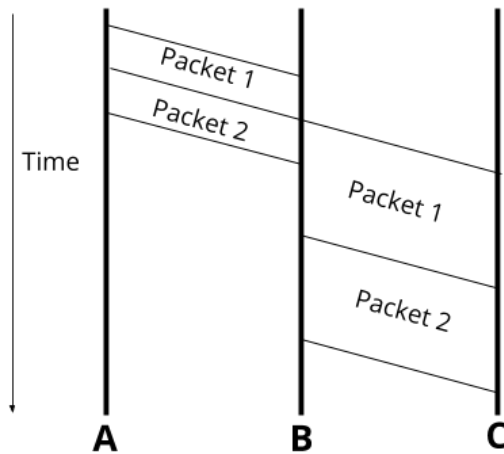

2.4 Find the variable relations that need to be satisfied in order to have no queuing delays for part (c).

From the analysis we conducted in part (c), we know there will be queuing delays if $t_1 > t_2$, or $\frac{8D_1}{T_2} > \frac{8D_2}{T_1}$. Hence, there are no queuing delays if: $\frac{8D_1}{T_2} \leq \frac{8D_2}{T_1}$ After simplifying, we see the relation that must be satisfied is:

$$\frac{D_1}{T_2} \leq \frac{D_2}{T_1}$$

3 Statistical Multi-What?

Consider three flows (F_1, F_2, F_3) sending packets over a single link. The sending pattern of each flow is described by how many packets it sends within each one-second interval; the table below shows these numbers for the first ten intervals. A perfectly smooth (i.e., non-bursty) flow would send the same number of packets in each interval, but our three flows are very bursty, with highly varying numbers of packets in each interval:

Time (s)	1	2	3	4	5	6	7	8	9	10
F_1	1	8	3	15	2	1	1	34	3	4
F_2	6	2	5	5	7	40	21	3	34	5
F_3	45	34	15	5	7	9	21	5	3	34

3.1 What is the peak rate of F_1 ? F_2 ? F_3 ? What is the sum of the peak rates?

The peak rate is the highest the flow gets throughout the whole period. The peak rate of F_1 is 34, the peak rate of F_2 is 40, and the peak rate of F_3 is 45.

The sum of their peaks is $34 + 40 + 45 = 119$.

3.2 Now consider all packets to be in the same aggregate flow. What is the peak rate of this aggregate flow?

Summing the flows together, we get the following values for an aggregate flow:

Time (s)	1	2	3	4	5	6	7	8	9	10
Aggregate Flow	52	44	23	25	16	50	43	42	40	43

The peak of the aggregate flow happens at 1s, where it is 52.

3.3 Which is higher - the sum of the peaks, or the peak of the aggregate?

The sum of the peaks is 119, whereas the peak of the aggregate is 52, so the sum of the peaks is much higher. This is the insight from Statistical Multiplexing! The peak of the aggregate can only be at most the sum of the peaks, but that only happens in the case that all of the peaks happen at the same time. This is very unlikely, so usually, the peak of the aggregate is much lower than the sum of the peaks.